

+ User Manual EE895

**Miniature Sensor Module for CO₂,
Temperature and Barometric Pressure**

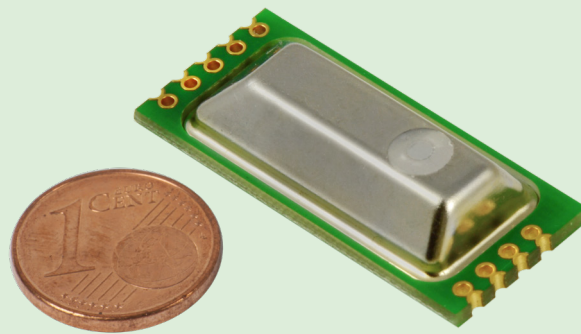

Content

1	General Information.....	3
1.1	Explanation of Warning Notices and Symbols.....	3
1.2	Safety Instructions	4
1.2.1.	General Safety Instructions	4
1.2.2.	Intended Use.....	4
1.2.3.	Mounting, Start-up and Operation.....	4
1.3	Environmental Aspects.....	5
1.4	ESD Protection	5
1.5	Product Description.....	5
1.6	Operating Principle CO ₂ Measurement	6
2	Handling Instructions.....	6
3	Hardware.....	7
3.1	Dimensions.....	7
3.2	Mounting Recommendation	7
3.2.1.	Mounting via Solder Pads.....	8
3.2.2.	Mounting via Side Plated Contacts.....	8
3.3	EE895 Block Diagram	9
3.5	Pin Description.....	10
3.6	Electrical Characteristics.....	12
3.7	Typical Applications.....	13
3.7.1.	EE895 Connected to USB Interface.....	13
3.7.2.	EE895 in Battery Powered Devices.....	13
3.7.3.	EE895 Connected to a KNX Bus	14
4	Digital Interface.....	14
4.1	I ² C Interface.....	14
4.1.1.	Modbus Protocol Over I ² C Interface	14
4.1.2.	I ² C Simplified Protocol.....	15
4.2	UART Interface	17
4.2.1.	Modbus Protocol Over UART Interface.....	17
4.3	Modbus Register Map	18
4.4	General Purpose Registers for Individual Use.....	18
4.5	EE895 Commands	19
4.5.1.	Information	19
4.5.2.	General Settings.....	19
4.5.3.	CO ₂ Parameter Settings	21
5	Technical Data	22
6	Conformity	24
6.1	ANSI/ASHRAE Standard 62.1-2022.....	24

1 General Information

This user manual is intended to ensure proper handling and optimal functioning of the device. The user manual shall be read before commissioning the equipment and it shall be provided to all staff involved in transport, installation, operation, maintenance and repair. E+E Elektronik Ges.m.b.H. accepts no liability for any warranty or liability claims arising from this publication or improper handling of the product(s) described.

All information, technical data and diagrams included in this document are based on the information available at the time of writing. The document may contain technical inaccuracies and typographical errors. The contents will be revised on a regular basis and changes will be implemented in subsequent versions. The product(s) described and the contents of this document may be changed or improved at any time without prior notice.

All rights are reserved by E+E Elektronik Ges.m.b.H. No part of this document may be reproduced, published or publicly displayed in any form or by any means, nor may its contents be modified, translated, adapted, sold or disclosed to a third party without prior written permission of E+E Elektronik Ges.m.b.H.

PLEASE NOTE

Find this document and further product information on our website at www.epluse.com/ee895.

1.1 Explanation of Warning Notices and Symbols

Safety precautions

Precautionary statements warn of hazards in handling the device and provide information on their prevention. The safety instruction labeling is classified by hazard severity and is divided into the following groups:

DANGER

Danger indicates hazards for persons. If the safety instruction marked in this way is not followed, the hazard will very likely result in severe injury or death.

WARNING

Warning indicates hazards for persons. If the safety instruction marked in this way is not followed, there is a risk of injury or death.

CAUTION

Caution indicates hazards for persons. If the safety instruction marked in this way is not followed, minor or moderate injuries may occur.

NOTICE

Notice signals danger to objects or data. If the notice is not observed, damage to property or data may occur.

Informative notes

Informative notes provide important information that is characterised by its relevance.

INFO

The information symbol indicates tips on handling the device or provides additional information on it. This information is useful to achieve optimum performance of the device.

The title field may deviate from "INFO" depending on the context. For instance, it may also read "PLEASE NOTE".

1.2 Safety Instructions

1.2.1. General Safety Instructions

NOTICE

Improper handling of the device may result in its damage.

- The EE895 enclosure and the circuit board shall not be exposed to unnecessary mechanical stress during installation and operation. The forces exerted shall not exceed 50 N.
- The EE895 electronics is sensitive to electrostatic discharge (ESD). Take appropriate protective measures when touching it.
- Use the EE895 only as intended and observe all technical specifications.

1.2.2. Intended Use

The EE895 miniature sensor module measures the CO₂ concentration, the temperature (T) and the absolute barometric pressure (p). It is intended to be used as sensor module in devices for diverse uses in non-condensing environments. Applications can be, e.g., in building automation, demand controlled ventilation and process control.

WARNING

Non-compliance with the product documentation may cause safety risk for people and the entire measurement installation.

The manufacturer is not liable for any damage caused by improper handling, installation and maintenance of the device.

- Do not use EE895 in explosive atmosphere or for measurement of aggressive gases.
- This device is not appropriate for safety, emergency stop or other critical applications where device malfunction or failure could cause injury to human beings.

NOTICE

Failure to follow the instructions in this user manual may lead to measurement inaccuracy and device malfunctions.

- The EE895 may only be operated under the conditions described in this user manual and within the specification included in chapter 5 Technical Data.
- The device may only be powered with safety extra-low voltage (SELV).
- Any unauthorised product modifications will invalidate all warranty claims. Modifications may only be carried out with the express authorisation of E+E Elektronik Ges.m.b.H.!

1.2.3. Mounting, Start-up and Operation

The EE895 has been produced under state of the art manufacturing conditions, has been thoroughly tested and has left the factory after fulfilling all safety criteria. The manufacturer has taken all precautions to ensure safe operation of the device. The device shall be set up and installed in a way that does not impair its safe use. All applicable local and international safety guidelines for safe installation and operation of the device have to be observed. This user manual contains information and warnings that must be observed in order to ensure safe operation.

PLEASE NOTE

The manufacturer or his authorised agent can only be held liable in case of willful or gross negligence. In any case, the scope of liability is limited to the corresponding amount of the order issued to the manufacturer. The manufacturer assumes no liability for damage caused by non-compliance with the applicable regulations, operating instructions or the specified operating conditions. Any consequential damage is excluded from liability.

⚠ WARNING

Non-compliance with the product documentation may cause accidents, personal injury or property damage.

- Mounting, installation, commissioning, start-up, operation and maintenance of the device may only be carried out by qualified staff. Such staff must be authorised by the operator of the facility to carry out the mentioned activities.
- The qualified staff must have read and understood this user manual and must follow the instructions contained within. The manufacturer accepts no responsibility for non-compliance with instructions, recommendations and warnings.
- All process and electrical connections must be thoroughly checked by authorised staff before commissioning the device.
- Do not install or start-up a device suspected to be faulty. Mark it clearly as faulty and remove it from the process.
- Service operations other than described in this user manual may only be performed by the manufacturer. A faulty device may only be investigated and possibly repaired by qualified, trained and authorised staff. If the fault cannot be fixed, the device shall be removed from the process.

1.3 Environmental Aspects

i PLEASE NOTE

Products from E+E Elektronik Ges.m.b.H. are developed and manufactured in compliance with all relevant environmental protection requirements. Please observe local regulations for the disposal of the device.



For disposal, the individual components of the device must be separated according to local recycling regulations. The electronics shall be disposed of correctly as electronics waste.

1.4 ESD Protection



The sensing elements and the electronics board are ESD (electrostatic discharge) sensitive components of the device and must be handled as such. The failure to do so may damage the device by electrostatic discharges when touching exposed sensitive components.

1.5 Product Description

Beside CO₂ concentration up to 10 000 ppm, the EE895 measures temperature (T) and absolute barometric pressure (p). The active pressure and temperature compensation minimises the impact of altitude and ambient conditions on the CO₂ measured data.

The CO₂, T and p measured data is available on I²C or UART digital interfaces. The solder pads, the plated half-holes and the through-holes allow for various mounting options.

The EE895 with CO₂ measuring ranges of 0...2 000 ppm and 0...5 000 ppm, complies with Addendum d to ANSI/ASHRAE Standard 62.1-2022, please refer to chapter 6 Conformity.

1.6 Operating Principle CO₂ Measurement

The CO₂ measurement is based on the dual wavelength Non Dispersive Infra-Red (NDIR) technology which compensates for ageing effects, is highly insensitive to pollution and offers outstanding long term stability.

The infrared detector 1 (IR-1) is tuned to 4.2 µm, which is the wavelength absorbed by CO₂, the infrared detector 2 (IR-2) is tuned to 3.9 µm, which is not affected by any gas. For every single flash of the infrared lamp (IR-L), the device calculates the CO₂ concentration from the outputs of both infrared detectors IR-1 and IR-2. The measuring interval is user selectable (factory default: 15 s).



2 Handling Instructions



EE895 is an ESD sensitive device and must be handled with corresponding precautions. Protect the sensor outside the EPA (Electrostatic Protected Area) using ESD protective packaging.

The EE895 is packed in stacks of ESD trays with 50 pieces each. The tray dimension is 354.2 x 278.6 x 23.8 mm (13.94 x 10.97 x 0.94 inch)

Operating and storage conditions: -40...+60 °C (-40...+140 °F)
 0...95 % RH (non-condensing)
 700...1 100 mbar (10.15...15.95 psi)

NOTICE

Failure to follow the instructions in this user manual may lead to measurement inaccuracy and device failures.

- The EE895 enclosure and the circuit board shall not be exposed to unnecessary mechanical stress during installation and operation. The forces exerted shall not exceed 50 N.
- The sensor module deploys a fine dust filter for sensing element protection. If the EE895 is deployed in a device which is designed for harsh environments, the device shall deploy a filter as well.

3 Hardware

3.1 Dimensions

Values in mm / inch

Side view

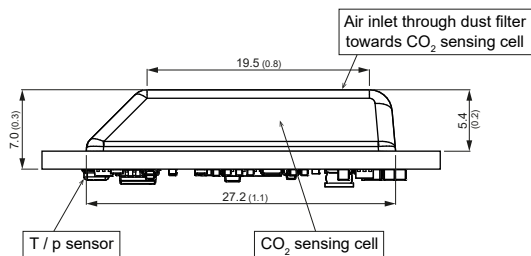

Bottom view

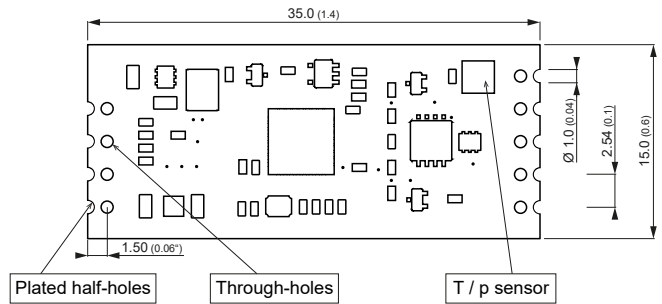

Recommended PCB footprint

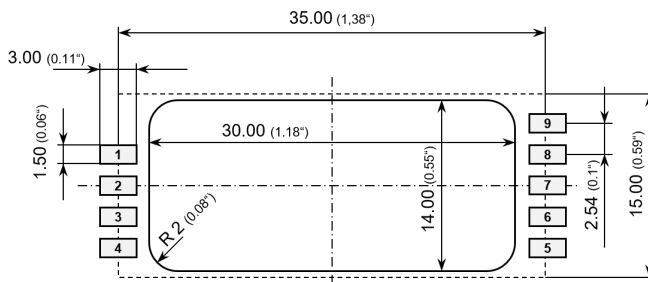

3.2 Mounting Recommendation

NOTICE

The EE895 is not intended for reflow soldering and consequently it does not feature a moisture sensitivity level rate (MSL). Nevertheless, for storage and handling it shall be regarded as compatible with MSL 1.

CAUTION

EE895 may only be soldered manually. A max. temperature of 360 °C may be applied for max. 10 s per solder point.



ESD precautions shall be observed while manually soldering the EE895. The EE895 can be mounted facing either upwards or downwards.

3.2.1. Mounting via Solder Pads

The EE895 module can be mounted onto a pluggable female header or directly onto the electronics board by using a pin-header with 2.54 mm (0.1 inch) pitch.

The minimum clearance of 2 mm (0.08 inch) shall be strictly observed. This is necessary for free air flow around the CO₂ sensing cell and around the T/p sensor.

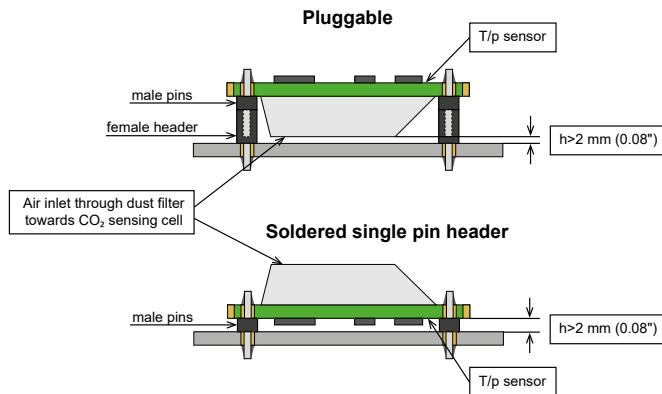

Fig. 1 Mounting with soldered pin header

3.2.2. Mounting via Side Plated Contacts

The EE895 can be mounted by manually soldering the plated half-holes onto the host board.

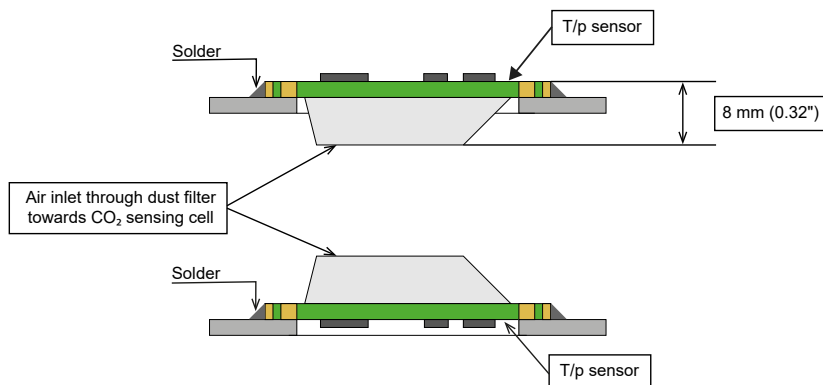

Fig. 2 Mounting by soldering at the side plated contacts

3.3 EE895 Block Diagram

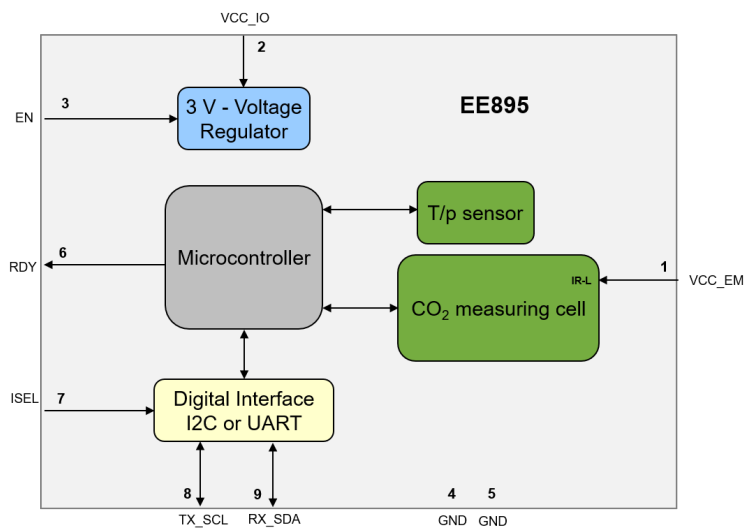

Fig. 3 Block diagram

3.4 Pin Assignment

Bottom view

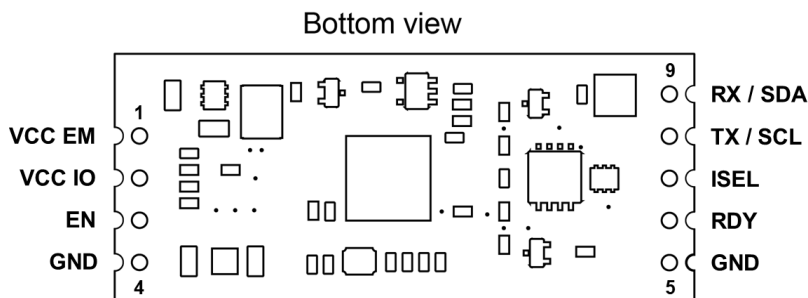

Fig. 4 Pin assignment

Pin no.	Name	Type	Comment
1	VCC_EM	Power supply	Power supply emitter infra-red lamp (IR-L)
2	VCC_IO	Power supply	Power supply for the microcontroller
3	EN	Input	Enable the module. Tie to Vcc_IO for normal operation
4	GND	Power supply	Ground ¹⁾
5	GND	Power supply	Ground ¹⁾
6	RDY	Output	Data ready (open drain output)
7	ISEL	Input	Interface selection
8	TX / SCL	I/O	Transmission line (TX) / Serial Clock (SCL)
9	RX / SDA	I/O	Receive line (RX) / Serial Data (SDA)

1) Pins 4 and 5 shall be connected to the same potential.

Tab. 1 Pin assignment

3.5 Pin Description

Pin 1 - VCC_EM

Power supply for the infrared lamp (IR-L). For optimising of the energy consumption such as in battery-powered devices, the IR-L can be powered separately.

The IR-L does not have to be powered continuously, as it needs power supply during the measurement cycle t_{meas} only, see Fig. 7. Between the measurement cycles the current consumption of IR-L is approx. 0.1 μ A.

Pin 2 - VCC_IO

Power supply for the microcontroller and the digital functional blocks.

Pin 3 – EN (Enable)

For battery-powered devices the user can optimise the energy consumption controlling the status of the EN pin by an external host controller.

When the EN pin is pulled-down to the logic Low 0 (≤ 0.4 V), the internal voltage regulator of EE895 is switched off and the current consumption is typically 1 μ A (max 2 μ A).

When pulled-up to the logic state High (≥ 0.9 V), the EE895 operates normally.

If the energy consumption of EE895 is not relevant, the EN pin shall be connected to VCC_IO.

The EN pin may not be left open.

Pin 6 – RDY (Data ready)

During the measurement cycle (t_{meas}), when CO₂, T and p are measured and processed, the pin RDY is in logic state High. As soon as data is available for read out, the pin RDY goes to logic state Low. The falling edge at this pin indicates that measured data is available for reading, see Fig. 5.

If used, an external pull-up resistor is required. If not used, the RDY pin may be left open.

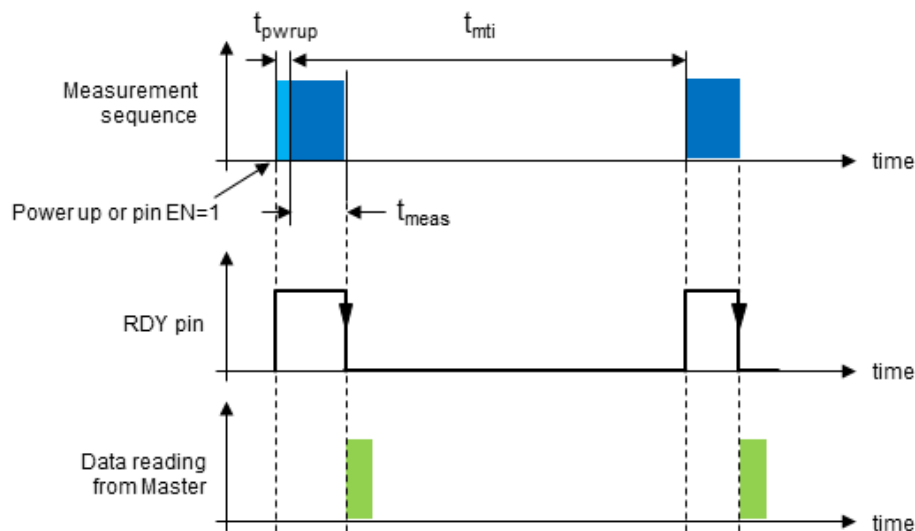

t_{pwrup}	power up time, approx. 150 ms
t_{meas}	measurement cycle (CO ₂ , RH, T,p) , approx. 300 ms warm-up + 300 ms IR lamp pulse
t_{mti}	measurement interval, user selectable 10...3600 s, +/-25 % (default: 15 s)

Fig. 5 Timing details (see also chapter 4.5.3. CO₂ Parameter Settings)

Pin 7 – ISEL (Interface selection)

The EE895 features I²C and UART interfaces.

Interface selection:

ISEL logic state	EE895 interface
Low (0...0.9 V)	I ² C
High (2.1...5.5 V) or not connected	UART

Tab. 2 Interface selection

Serial interface pins:

Pin 8 – TX_SCL Transmission data / Serial clock

Pin 9 – RX_SDA Receiving data / Serial data

The function of pins 8 and 9 depends on the interface selected with pin 7 ISEL.

Pin 7 – ISEL connected to ground: EE895 features I²C interface:

Pin no.	Mode	Comment
8	SCL (serial clock)	External pull-up resistor to V+ (bus high voltage level) is required.
9	SDA (serial data)	External pull-up resistor to V+ (bus high voltage level) is required.

Tab. 3 Pin assignment I²C interface

Example:

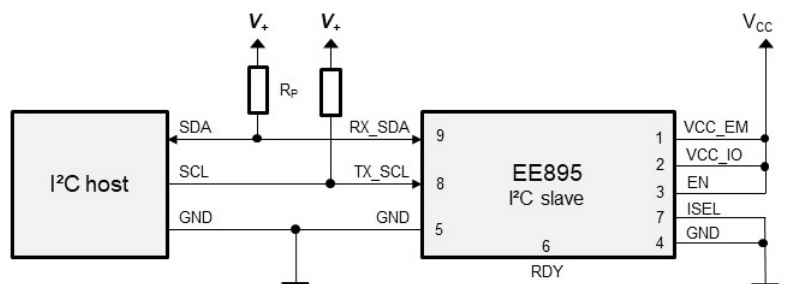

- V_{CC} = EE895 supply voltage: 3.3 – 5.5 V
- V₊ = Bus high voltage, typical 3.3 - 5.5 V
- R_p = I²C pull-up resistors, typical 10 kΩ
- V₊ and V_{CC} are independent but may be connected together
- Independently of V_{CC}, RX_SDA and TX_SCL pins are 5 V tolerant (max 5.5V)

Fig. 6 Example I²C interface

Pin 7 – ISEL connected to V_{CC} or left open: EE895 features UART interface:

Pin no.	Mode	Comment
8	TX (transmission line)	CMOS compatible (V _{OutLowMax} 0.4 V; V _{OutHighMin} 2.6 V)
9	RX (receive line)	CMOS compatible (V _{InputLowMax} 0.9 V; V _{InputHighMin} 2.1 V)

Tab. 4 Pin assignment UART interface

Example:

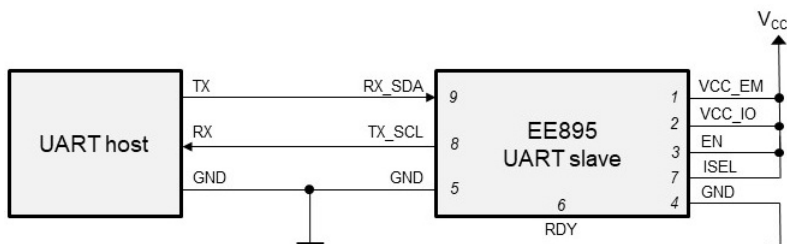

- V_{CC} = EE895 supply voltage: 3.3 – 5.5 V
- Independently of V_{CC}, RX_SDA pin is 5 V tolerant (5.5 V max)
- EE895 internal microcontroller uses 3 V supply
- RX_SDA/ TX_SCL pins are CMOS compatible:
 - RX_SDA V_{InputLowMax} = 0.9 V; V_{InputHighMin} = 2.1 V
 - TX_SCL V_{OutLowMax} = 0.4 V; V_{OutHighMin} = 2.6 V @ 8 mA

Fig. 7 Example UART interface

3.6 Electrical Characteristics

A DC/DC converter is used to flash the lamp (VCC_EM). Therefore, the supply current is reduced with higher voltage and vice versa. The microcontroller (VCC_IO) is supplied via a linear regulator, hence the supply current is constant.

The average current consumption at a sampling interval of 15 s (factory default) is 1.6 mA. Tab. 5 lists the typical and maximum current values in each individual state during the sampling interval, which is shown in the current profile in Fig. 8.

Status	Power Supply	VCC_IO	VCC_EM	
			3.3 V	5 V
Idle measurement		6.2 (9.9) mA	<0.1 µA	<0.1 µA
IR lamp pulse		6.2 (9.9) mA	85 (95) mA	60 (66) mA
Standby		190 (300) µA	<0.1 µA	<0.1 µA
Power off		<2 µA	<0.1 µA	<0.1 µA

Tab. 5 Current values in the individual measurement states, typ. (max.)

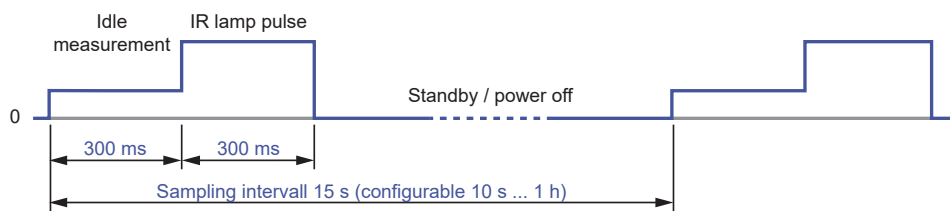

Fig. 8 States during a CO₂ sampling interval

Further electrical characteristics:

Signal	Unit	Min	Max	Note
Clock frequency	Hz	500	100 000	
Pull-up resistor	kΩ	4.7	100	Typical 10 kΩ

Tab. 6 Electrical characteristics

3.7 Typical Applications

3.7.1. EE895 Connected to USB Interface

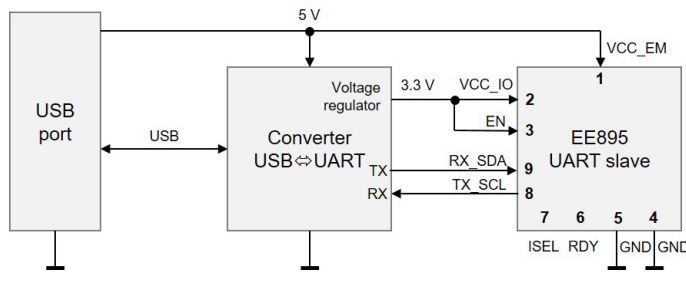

Fig. 9 Example USB Interface

Pin 7 - ISEL is not connected → the EE895 features UART interface.

VCC_EM is connected to the nominal 5 V from USB, the VCC_IO and EN are connected to 3.3 V voltage regulator.

The host can read the values at any time, pin 6 - RDY is not used.

3.7.2. EE895 in Battery Powered Devices

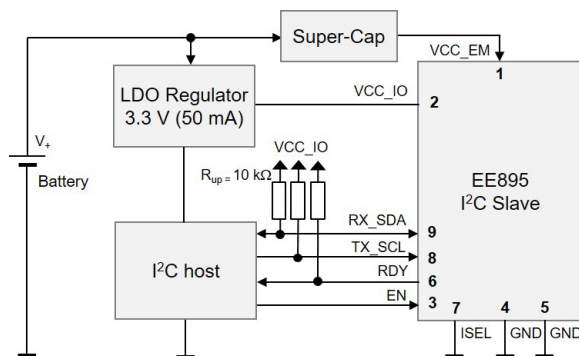

Fig. 10 Example battery powered devices

Pin 7 - ISEL is connected to the ground → the EE895 features I²C interface.

VCC_EM is supplied by a low ESR super-capacitor and VCC_IO is connected to a typical low drop 3.3 V regulator.

The I²C host enables the EE895 with pin 3 - EN.

By checking the status of pin 6 - RDY (pulled up), the host can read the data as soon as available. After reading the data, EE895 can be disabled with pin 3.

3.7.3. EE895 Connected to a KNX Bus

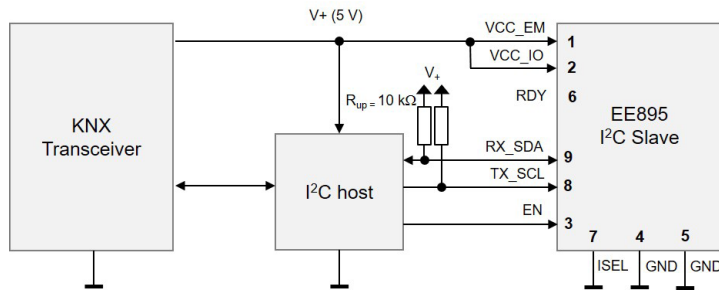

Fig. 11 Example KNX Bus

Pin 7 - ISEL is connected to the ground → the EE895 features I²C interface.

The VCC_EM and the VCC_IO are connected to the typical 5 V bus voltage.

The I²C host keeps the EE895 enabled with the pin 3 – EN and can read the values at any time, pin 6 - RDY is not used.

4 Digital Interface

The EE895 features standard I²C and UART interfaces. The interface selection is made with pin 7 – ISEL, see Tab. 2 Interface selection. On both interfaces, I²C and UART, the data is encapsulated in Modbus Protocol Data Units (Modbus PDUs).

i PLEASE NOTE

Modbus implementation details and request/response examples are described in detail in the Modbus Application Note AN0103 (available at www.epluse.com/ee895).

4.1 I²C Interface

The EE895 supports the standard I²C specification. For detailed information about the I²C interface, please refer to NXP document „I²C-bus specification and user manual“, Rev. 6, 4 April 2014:

<https://www.nxp.com/docs/en/user-guide/UM10204.pdf>

The I²C interface simultaneously supports two protocols on two different slave addresses:

- Modbus over I²C address 0x5F
- I²C simplified address 0x5E

These addresses are fixed, they cannot be changed by the user.

4.1.1. Modbus Protocol Over I²C Interface

I²C slave address: 0x5F

The I²C interface encapsulates the data according Modbus PDU packets, including CRC:

S	Slave Address	W	A	Request: Modbus PDU + Modbus CRC	P
S	Slave Address	R	A	Response: Modbus PDU + Modbus CRC	P

Every byte of the Modbus PDU and the Modbus CRC must be acknowledged (according to I²C specification, not shown above).

The EE895 module supports repeated START or STOP conditions between the request packet and the response packet. If a START condition and an address match are detected, the EE895 will stay active until a STOP condition is received or an idle timeout of 500 ms occurs. This might increase the power consumption and self-heating. The I²C master shall ensure that the data is retrieved as soon as possible in case of a repeated START.

For the Modbus register map please refer to chapter 4.3 Modbus Register Map.

NOTICE

The CRC16 shall be calculated including the unshifted slave address.

Example of command reading the temperature (floating point value) T = 25.30 °C from the register 0x3EA:

EE895

Request [Hex]: S BE 03 03 EA 00 02 E8 C5 P										
Start	Slave address 7-bit shifted	Function code	Starting address Hi	Starting address Lo	Qty. of registers Hi	Qty. of registers Lo	CRC		Stop	
S	BE	03	03	EA	00	02	E8	C5	P	

Response [Hex]: S BF 03 04 00 00 41 DC 74 3F P										
Start	Slave address 7-bit shifted	Function code	Byte count	Register 1 value Hi	Register 1 value Lo	Register 2 value Hi	Register 2 value Lo	CRC		Stop
S	BF	03	04	00	00	41	DC	74	3F	P

For decoding of float values stored according standard IEEE 754, please refer also to the Modbus Application Note AN0103.

Example of Decoding:

Modbus response [Hex]				
Byte 1	Byte 2	Byte 3	Byte 4	Decimal value
41	DC	00	00	27.50

i PLEASE NOTE

For obtaining the correct value, both registers have to be read with a single request. The measured value can change between two Modbus requests. Exponent and mantissa may get inconsistent in this case.

4.1.2. I²C Simplified Protocol

I²C slave address: 0x5E

This I²C protocol is intended for I²C master reading the measured values from EE895 in “EEPROM-like-mode”.

The simplified I²C does not support any error detection (such as CRC) and provides the measured data in 8 subsequent registers, as 16 bit integers.

Slave address	0x00	0x01	0x02	0x03	0x04	0x05	0x06	0x07
0x5E	CO ₂ high byte	CO ₂ low byte	T high byte	T low byte	reserved*) high byte	reserved*) low byte	p high byte	p low byte

*) Reserved for future use

The read pointer is the first register to be set. Additional bytes are answered by the EE895 module with NACK. If more bytes are read than the 8 registers, the EE895 answers with 0xFF (i.e. the SDA line is not pulled down). If a START condition and an address match are detected, the EE895 will stay active until a STOP condition is received or an idle timeout of 500 ms occurs.

The measured data is available as a 16 bit integer and is expressed in SI units:

Measurand	Register pointer	Unit	Scale
CO ₂ average, pc ¹⁾	0x00	ppm	1:1
T	0x02	°C	1:100 *)
p	0x06	mbar	1:10 **)
CO ₂ average, npc ²⁾	0x08	ppm	1:1
CO ₂ raw, pc ¹⁾	0x0A	ppm	1:1
CO ₂ raw, npc ²⁾	0x0C	ppm	1:1

1) pc ... pressure compensated
 2) npc ... not pressure compensated
 *) Example: 2 575 means 25.75 °C
 **) Example: 10 130 means 1 013 mbar

Tab. 7 Data availability from the EE895 Miniature Sensor Module

Example for reading all measurands (7-bit address shifted):

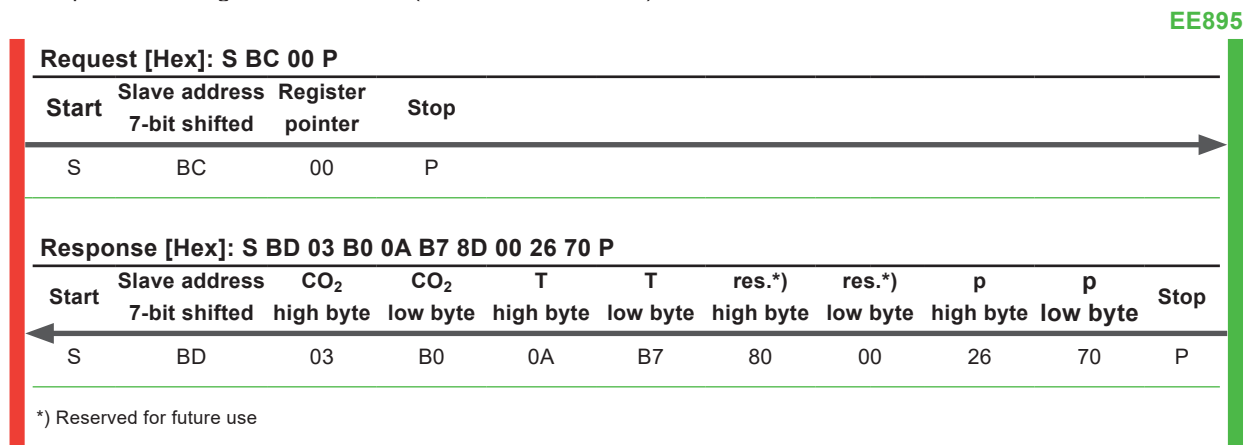

Conversion:

Measurand	Response [Hex]	Response [Dec]	Value
CO ₂	0x03B0	944	944 ppm
T	0x0AB7	2743	27.43 °C
p	0x2670	9840	984.0 mbar

Tab. 8 Interpretation of data from the response

4.3 Modbus Register Map

Following Modbus register map is valid for both, the I²C and the UART interface. The measured data is saved as 32 bit floating point values (data type FLOAT) and as 16 bit signed integer values (data type INTEGER), please refer to Tab. 10 and Tab. 11 below:

FLOAT 32

Parameter	Unit	Register number ¹⁾ [DEC]	Register address ²⁾ [HEX]
Read register: function code 0x03			
Temperature T	°C	1003	0x3EA
Temperature T	°F	1005	0x3EC
Temperature T	K	1009	0x3F0
CO ₂ (average), pc ³⁾	ppm	1061	0x424
CO ₂ (raw), pc ³⁾	ppm	1063	0x426
CO ₂ (average), npc ⁴⁾	ppm	1065	0x428
CO ₂ (raw), npc ⁴⁾	ppm	1067	0x42A
Pressure p	mbar	1201	0x4B0
Pressure p	psi	1203	0x4B2

- 1) Register number starts from 1
- 2) Register address starts from 0
- 3) pc ... pressure compensated
- 4) npc ... not pressure compensated

Tab. 10 I²C and UART Modbus register map for 32 bit floating point values

INT16

Parameter	Unit	Scale ³⁾	Register number ¹⁾ [DEC]	Protocol address ²⁾ [HEX]
Read register: function code 0x03				
Temperature T	°C	100	4002	0xFA1
Temperature T	°F	50	4003	0xFA2
Temperature T	K	50	4005	0xFA4
CO ₂ (average), pc ⁴⁾	ppm	1	4031	0xFBE
CO ₂ (raw), pc ⁴⁾	ppm	1	4032	0xFBF
CO ₂ (average), npc ⁵⁾	ppm	1	4033	0xFC0
CO ₂ (raw), npc ⁵⁾	ppm	1	4034	0xFC1
Pressure p	mbar	10	4101	0x1004
Pressure p	psi	100	4102	0x1005

- 1) Register number starts from 1
- 2) Register address starts from 0
- 3) Examples: For scale 100, the reading of 2550 means a value of 25.5. For scale 50, the reading of 2550 means a value of 51.
- 4) pc ... pressure compensated
- 5) npc ... not pressure compensated

Tab. 11 I²C and UART Modbus register map for 16 bit signed integer values

4.4 General Purpose Registers for Individual Use

There are two registers reserved for any customer use, e.g. serial number, traceability, etc.

Register number ¹⁾ [DEC]	Register address ²⁾ [HEX]	Space (standard Modbus register)
Write register: function code 0x06 / Read register: function code 0x03		
5801	0x16A8	16 bits / 2x8 bits / 2 bytes
5802	0x16A9	16 bits / 2x8 bits / 2 bytes

- 1) Register number starts from 1
- 2) Register address starts from 0

Tab. 12 Registers for special customer purpose

4.5 EE895 Commands

The following commands are available via Modbus over I²C and Modbus over UART.

i PLEASE NOTE

I²C simplified does not support Modbus encapsulation. Therefore, no Modbus communication and no settings are possible.

4.5.1. Information

Function code	Register address ¹⁾ [HEX]	Description	Note
0x03	0x00	Serial number	EE895 serial number, ASCII, 0 terminated
	0x08	FW-Version (Major, Minor)	High-Byte = Major Version Low-Byte = Minor Version Example: 0x011A = 1.26 [01=1; 1A=26]
	0x09	Sensor name	2 ASCII characters for each Register ("EE895") String is 0-terminated

¹⁾ Register address starts from 0

Tab. 13 Available commands for I²C and UART

i PLEASE NOTE

When reading the serial number or the sensor name, it is always necessary to read all 8 registers, even if the desired information requires less.

4.5.2. General Settings

The following functions allow for EE895 settings. These are stored in the RAM, therefore they are volatile.

Measuring mode: continuous or single shot

Function code	Register address ¹⁾ [HEX]	Note
Read 0x03 Write 0x06	0x1F8	[Bit 0] Default status = 0 0 = continuous. The EE895 measures at the regular interval set with the command "CO ₂ measuring interval", see chapter 4.5.3. 1 = single shot. The EE895 measures only with the command "Measuring trigger", see below. [Bit 1..15] reserved (must be written as 0)

¹⁾ Register address starts from 0

Tab. 14 Continuous or single shot measurement

Measuring status: indicates when new single shot measurement is possible.

Function code	Register address ¹⁾ [HEX]	Note
0x03	0x1F9	[Bit 0]: Data ready. The data are available for read out. 0 = busy, 1 = ready [Bit 1]: Trigger ready. The EE895 is ready for new measurement cycle. The minimum time interval between two triggers is 10 s. 0 = trigger not possible 1 = ready for new trigger [Bit 2..15] reserved (do not use)

1) Register address starts from 0

Tab. 15 Single shot measurement possible

Measuring trigger: command for the single shot measurement. For accurate measurement results, there are recommended six single shot measurements under stable temperature conditions.

Function code	Register address ¹⁾ [HEX]	Note
0x06	0x1FA	[Bit 0]: Measurement Trigger 0 = don't care 1 = Start new measurement cycle [Bit 1..15] reserved (must be written as 0)

1) Register address starts from 0

Tab. 16 Command single shot measurement

EE895 detailed status

Function code	Register address ¹⁾ [HEX]	Note
0x03	0x258	[Bit 0]: CO ₂ measurement too high [Bit 1]: CO ₂ measurement too low [Bit 2]: T measurement too high [Bit 3]: T measurement too low [Bit 6]: p measurement too high [Bit 7]: p measurement too low [Bit 8...15]: reserved (do not use)

1) Register address starts from 0

Tab. 17 Status details

4.5.3. CO₂ Parameter Settings

The CO₂ parameter settings are non-volatile since they are stored in the flash memory.

Function code	Register address ¹⁾ [HEX]	Description	Unit	Note
0x06	0x1450	CO ₂ measuring interval	S	16 bit integer unsigned Scale 1:10. Example: 150 = 15 seconds Range 100...36 000 Default 15 s
	0x1451	CO ₂ filter coefficient*)	-	16 bit integer unsigned Range 1...20 Default: 4
	0x1452	CO ₂ customer offset	ppm	16 bit integer signed Range -32 786...32 785 Default: 0 ppm

1) Register address starts from 0

Tab. 18 CO₂ parameter settings

*) The EE895 features an exponential moving average filter which to a certain degree suppresses the influence of short-term CO₂ variations onto the output CO₂ data. The filter coefficient is user selectable and affects the response time of the EE895. A higher filter coefficient leads to smoother output data and to longer response time, see figure Fig. 12. Fig. 13 shows the number of samples required to reach 63% or 90% of a CO₂ step as function of the filter coefficient.

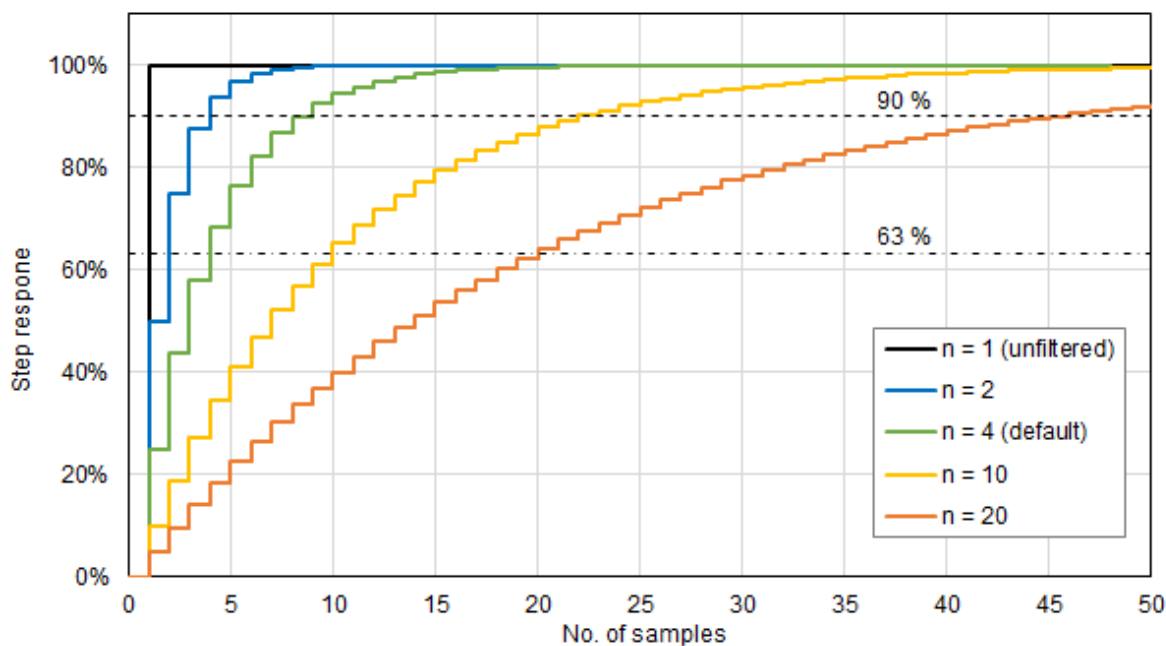

Fig. 12 Step response vs. samples

Pressure (p)

Working range	700...1 100 mbar (10.15...15.95 psi)
Accuracy, typ. @ 25 °C (77 °F)	±2 mbar (20...80 %RH)
Temperature dependency, typ.	±0.015 mbar/K

Temperature (T)

Measuring range	-40...+60 °C (-40...+140 °F)
Accuracy @ 25 °C (77 °F)	±0.5 °C (±0.9 °F)

General

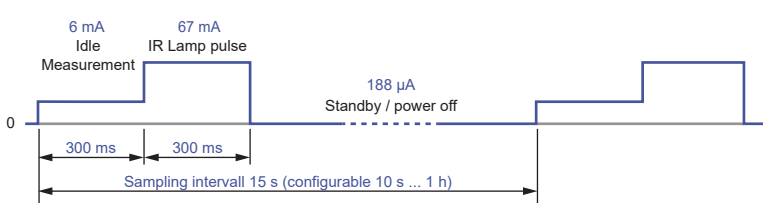
Digital interface (pin-selectable)	I²C UART	Up to 100 kbit/s 9 600 Baud, 8 bits, no parity, 1 stop bit
Module control	Enable pin Data ready pin	Continuous operation / power down Indication of valid data
Supply voltage		3.3 - 5 V DC ± 5 %
Average current consumption, typ. for supply voltage 5 V		1.6 mA at 15 s sampling interval 196 µA at 1 h sampling interval with standby between measurements 8 µA at 1h sampling interval with power down between measurements
Current profile CO₂ typical values for supply voltage 5 V		
Electrical connection		Side plated contacts and solder pads, Ø 1 mm (0.04")
Working and storage conditions		-40...+60 °C (-40...+140 °F) 0...95 %RH (non-condensing) 700...1 100 mbar (10...16 psi)

Accuracy of E+E CO₂ Sensors

The measurement accuracy depends both on the performance of the measuring instrument and on the correct installation in the application.

For best accuracy, every E+E CO₂ sensor is multi-point factory adjusted and calibrated in a highly stable reactor. The overall uncertainty of the factory calibration U_{cal} is minimal.

The total measurement uncertainty U_{total} for E+E sensors is calculated in accordance with EA-4/02 (European Accreditation, Evaluation of the Measurement Uncertainty in Calibration) and with GUM (Guide to the Expression of Uncertainty in Measurement) as follows:

$$U_{total} = k \cdot \sqrt{\left(\frac{U_{cal}}{2}\right)^2 + \left(\frac{U_{accuracy}}{2}\right)^2}$$

U_{total} total accuracy incl. factory calibration

U_{cal} uncertainty of the factory calibration

$U_{accuracy}$ accuracy of the measurement device

k coverage factor $k=2$, corresponding to a confidence level of 95 %.

For external calibrations, U_{total} is to be used as the evaluation criterion. The calculation does not include effects due to long-term drift or chemical exposure.

6 Conformity

6.1 ANSI/ASHRAE Standard 62.1-2022

The EE895 sensors with the CO₂ measuring ranges 0...2 000 ppm and 0...5 000 ppm, comply with Addendum d to ANSI/ASHRAE Standard 62.1-2022 released on 31 March 2025 by ASHRAE and the American National Standards Institute.

The accuracy requirements of ± 30 ppm ± 3 % of the measured value are met at CO₂ concentrations of 600, 1 000 and 2 500 ppm, for a measurement at sea level at 25 °C (77 °F). In building automation environment, the sensor requires calibration not more frequently than once every five years.



Company Headquarters &
Production Site

E+E Elektronik Ges.m.b.H.
Langwiesen 7
4209 Engerwitzdorf | Austria
T +43 7235 605-0
F +43 7235 605-8
info@epluse.com
www.epluse.com

Subsidiaries

E+E Sensor Technology (Shanghai) Co., Ltd.
T +86 21 6117 6129
info@epluse.cn

E+E Elektronik France SARL
T +33 4 74 72 35 82
info.fr@epluse.com

E+E Elektronik Deutschland GmbH
T +49 6171 69411-0
info.de@epluse.com

E+E Elektronik India Private Limited
T +91 990 440 5400
info.in@epluse.com

E+E Elektronik Italia S.r.l.
T +39 02 2707 86 36
info.it@epluse.com

E+E Elektronik Korea Ltd.
T +82 31 732 6050
info.kr@epluse.com

E+E Elektronik Corporation
T +1 847 490 0520
info.us@epluse.com



—
your partner
in sensor
technology.